

STANDARD DESIGN OFFSET INLET SPECIAL

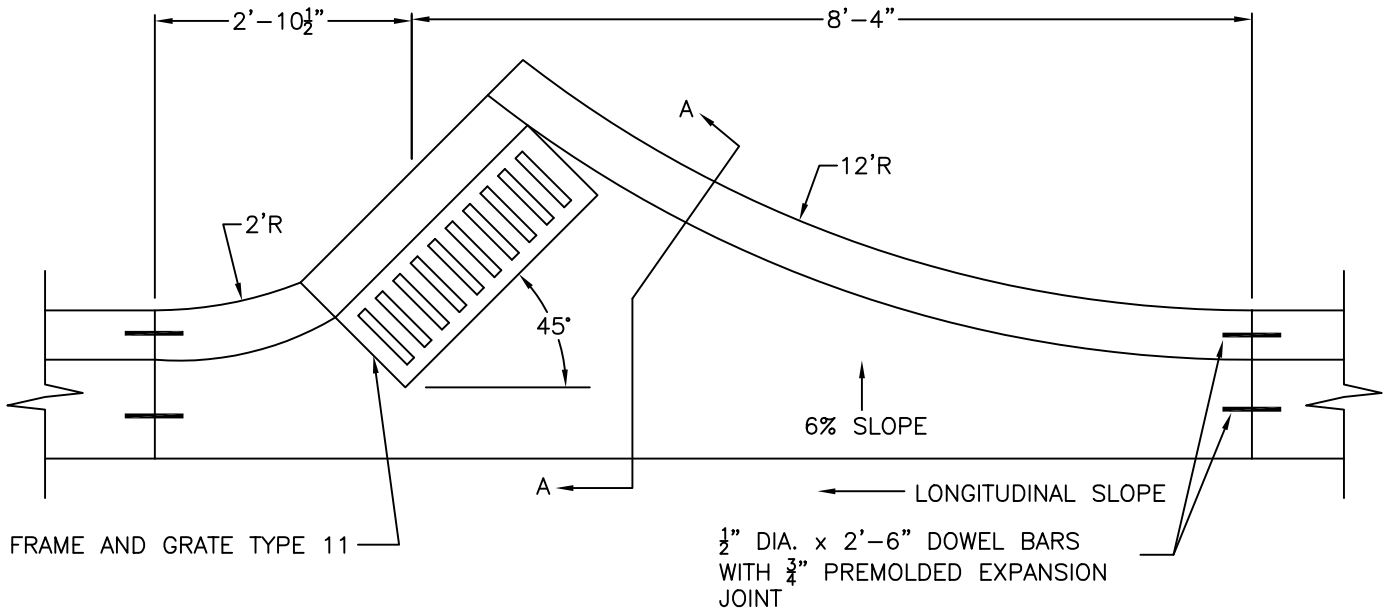

PLAN

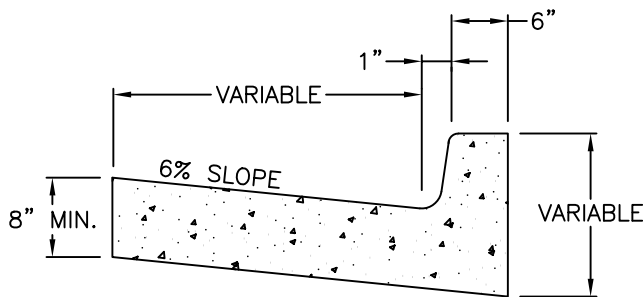

SECTION A-A

NOTES:

1. CONSTRUCTION JOINTS OF A TYPE SIMILAR TO THAT USED IN THE ADJACENT PAVEMENT SHALL BE INSTALLED IN THE OFFSET INLET SPECIAL IN PROLONGATION WITH THE PAVEMENT JOINTS.
2. CLASS "SI" CONCRETE SHALL BE USED THROUGHOUT.
3. IF CONTRACTION JOINTS ARE NOT PROVIDED IN THE PAVEMENT, CONTRACTION JOINTS ARE NOT REQUIRED IN THE OFFSET INLET SPECIAL.
4. TO BE USED WHERE LONGITUDINAL GRADE OF STREET EXCEEDS 2% OR IN SPECIAL CASES WHERE INCREASED EFFICIENCY IS REQUIRED.

CITY OF DECATUR, ILLINOIS
DEPARTMENT OF ENGINEERING
& INFRASTRUCTURE

ADOPTED JANUARY 1, 2003

DIRECTOR OF ENGINEERING & INFRASTRUCTURE

ISSUED: 7-3-78	
REVISIONS	
BY	DATE
F.W.T.	12/15/81
SHOE	9/15/89
JMM	11/5/02

STANDARD 3060