

STANDARD DESIGN FOR DRIVEWAY AND PAVEMENT PATCHING

EXISTING PAVEMENT	REPLACEMENT MATERIALS
STONE	8" AGGREGATE SURFACE COURSE TYPE B
FLEXIBLE PAVEMENTS	BITUMINOUS CONCRETE SURFACE COURSE WILL BE 2" GREATER THAN EXISTING OR MINIMUM OF 8" (SEE NOTE B)
RIGID PAVEMENTS	P.C.C. PAVEMENT WILL BE 2" GREATER THAN EXISTING OR 8" MIN. (SEE NOTE C)
RIGID DRIVEWAY PAVEMENTS	DRIVEWAY PAVEMENT WILL BE 2" GREATER THAN EXISTING OR 6" MIN.

NOTE: THE PAVEMENT REPLACEMENTS SHOWN ARE MINIMUMS, THE EXISTING PAVEMENT SECTION SHALL DICTATE THE EXACT THICKNESS WHEN GREATER THAN SHOWN ABOVE.

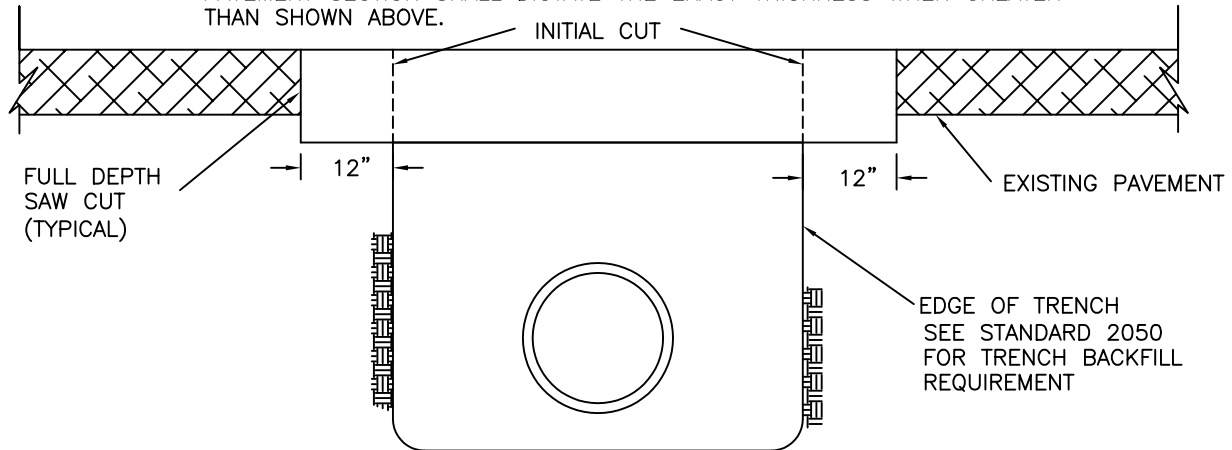

CONSTRUCTION PROCEDURE-RIGID & FLEXIBLE PAVEMENTS

- A. RIGID AND FLEXIBLE PAVEMENTS
1. THE INITIAL CUT LINE SHALL BE OUTLINED WITH A SAW CUT OF SUFFICIENT DEPTH TO INSURE THAT THE PAVEMENT TO BE REMOVED CAN BE BROKEN AWAY WITHOUT STRUCTURAL DAMAGE TO THE PAVEMENT REMAINING.
 2. THE FINAL SAW CUT LINE SHALL BE MADE BY SAWING FULL DEPTH A MINIMUM OF 1 FT. BEYOND ANY PAVEMENT DAMAGE AND SHALL BE MADE AFTER THE TRENCH HAS BEEN FILLED AND COMPACTED.
 3. AFTER THE PAVEMENT HAS BEEN REPLACED, THE PERIMETER OF THE SAW JOINT SHALL BE SEALED BY AN APPLICATION OF BITUMINOUS MATERIAL.
- B. BITUMINOUS CONCRETE PAVEMENT
1. PRIOR TO PATCHING A HOLE, THE CUT FACES OF THE EXISTING PAVEMENT AND COMPACTED BASE COURSE SHALL BE GIVEN AN APPLICATION OF ASPHALT RC-70 AT THE RATE OF APPROXIMATELY 0.1 GALLONS PER SQUARE YARD.
 2. THE PATCHING MATERIAL SHALL BE BITUMINOUS CONCRETE SURFACE COURSE, CLASS I, AND SHALL BE PLACED IN ACCORDANCE TO IDOT STANDARD SPECIFICATIONS FOR ROAD AND BRIDGE CONSTRUCTION CURRENT VERSION FOR CLASS D PATCHES.
- C. PORTLAND CEMENT CONCRETE PAVEMENT
1. REPAIRS IN PCC PAVEMENT GREATER THAN 6" IN DEPTH WILL BE CONSTRUCTED IN ACCORDANCE WITH CITY STANDARD #1060.
- D. BRICK PAVEMENT
1. REPAIRS WILL BE MADE IN ACCORDANCE WITH CITY STANDARD #1070 FOR BRICK PAVEMENT REPAIRS OR AS DIRECTED BY THE CITY ENGINEER.

CITY OF DECATUR, ILLINOIS
DEPARTMENT OF ENGINEERING
& INFRASTRUCTURE

ADOPTED JANUARY 1, 2003

DIRECTOR OF ENGINEERING & INFRASTRUCTURE

ISSUED: 7-3-01

REVISIONS
BY DATE

R.W.D.	3/3/97
K.G.Q.	4/3/00
JMM	5/1/02
KSG	10/2002

STANDARD#1050